

**SUBMITTAL RECORD**

JOB \_\_\_\_\_  
 LOCATION \_\_\_\_\_  
 SUBMITTED TO \_\_\_\_\_  
 SUBMITTAL PREPARED BY \_\_\_\_\_  
 APPROVED BY \_\_\_\_\_  
 DATE \_\_\_\_\_



# Submittal Form

## OBD/PBD (L.L.)

### Low Leakage Control Damper

**Standard Construction:**

**Frame:** Roll-formed galvanized steel hat-section with staked corners and integral bracing  
**Blades:** 16ga (3V) Roll-formed galvanized steel. 5.25" wide standard.  
**Bearings:** Bronze Oilite, press-fit into frame  
**Axles:** 3/8" square plated steel  
**Seals:** Extruded vinyl for 50°F-250°F  
**Linkage:** Concealed in frame. Linkage bars are .125" thick plated steel  
**Finish:** Mill Finish  
**Extended Drive Pin:** Removable 1/2" round diameter, plated steel

**Note:** Dampers are furnished approximately .25" (6mm) smaller than given duct dimensions. Not recommended with blades running vertically.

**Sizes:** Minimum size: 8" W x 8" H

Single Section: 48" W x 48" H

Multiple Section:

Size unlimited

- Dampers are supplied with jackshifting (contact Duro Dyne for specifics on sizes)

Note: Actuators for control dampers to be supplied by Controls' Contractor

**Options:**

- Quadrant (Volume Damper)
- Extended 9" Shaft
- Aluminum Construction
- Stainless Steel

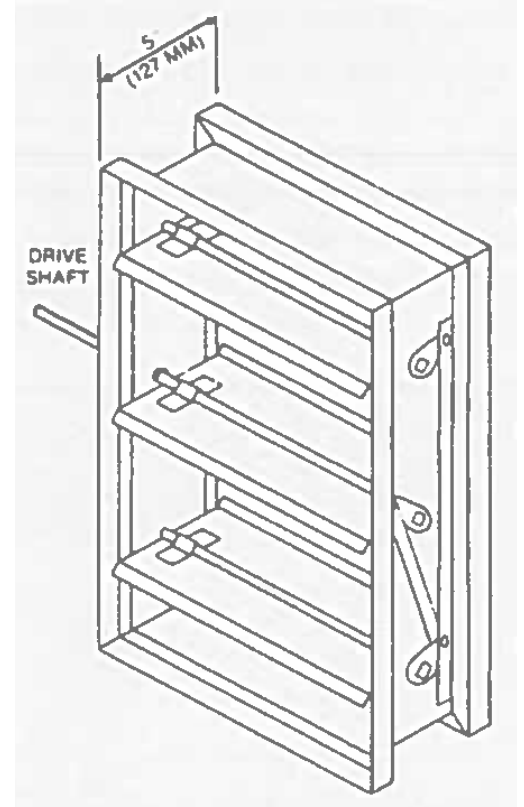
**Features:**

- The OBD/PBD series Control Dampers have been designed and tested to provide an extremely tight sealing damper which is cost effective for the majority of HVAC applications. They are generally recommended for the face velocities up to 1,500 fpm and static pressure to 2.5" w.g. (Note :For systems in excess of 2.5" w.g. contact the factory.)
- The OBD/PBD(L.L.) series dampers have inflatable (pressure-sensitive) jamb and blade edge seals to provide the ultimate in sealing characteristics without unduly increasing torque requirements.
- The OBD/PBD damper's rigid frame and integrally braced comers provide true damper alignment that greatly resists being installed out of square or out of flat. This ensures on-site performance equal to test results.
- The OBD/PBD dampers have been tested to AMCA standard 500 with the following results:
 

LEAKAGE	1.0" w.g.	2.5" w.g.	4.0" w.g.
Cfm/Sq.Ft.	3.5	5.0	7.0
- OBD/PBD is available in either parallel blade or opposed blade models.
- OBD/PBD is available as a face and bypass mixing damper.
- Dampers less than 8" (203mm) in height are furnished with low-profile flat top and bottom to maximize free area.

**SUGGESTED SPECIFICATIONS**

Low Leakage Control Dampers shall be Duro Dyne Model: OBD/PBD (L.L.) type dampers. Both blade and jamb seals shall be of the inflatable, pressure sensitive type for low leakage. Dampers shall be rated to leakage to AMCA 500. Leakage shall not exceed 5 cfrn/sq.ft. and 2.5" S.P.

Duro Dyne National Corporate Headquarters, Bay Shore, NY  
 631-249-9000 • Fax: 631-249-8346  
 Duro Dyne Midwest • Duro Dyne West • Duro Dyne Canada  
 www.durodyne.com • E-mail: durodyne@durodyne.com



2/13/2023