

**SUBMITTAL RECORD**

JOB \_\_\_\_\_  
LOCATION \_\_\_\_\_  
SUBMITTED TO \_\_\_\_\_  
SUBMITTAL PREPARED BY \_\_\_\_\_  
APPROVED BY \_\_\_\_\_  
DATE \_\_\_\_\_



**Submittal Form**

**FSD-3V-231**

**Combination Fire / Smoke Damper**

U.L. 555S Classified /  
Class I U.L. 555 Classified 3 Hours  
U.L.C. S112 Classified 3 Hours  
Vertical and Horizontal Mountings

Accepted for use City of New York  
Department of Buildings  
MEA#: 302-00-M

Approved by the Board of Standards  
and Appeals for use  
in New York City  
Cal. 291-80-SA

U.L. 555S Classified  
at 250°F or 350°F  
depending upon Motor/Operator  
\*See Motor/Operator Schedule



**Standard Construction:**

**Frame:** Roll-formed galvanized steel hat-section with staked corners and integral bracing

**Blades:** 16ga (3V) Roll-formed galvanized steel

**Minimum width:** 4.250"

**Maximum width:** 7.250"

**Bearings:** Bronze Oilite, press-fit into frame

**Axles:** Square, plated steel

**Seals:** Pressure sensitive 450°F silicone blade edge seals and flexible metal jamb seal

**Linkage:** Concealed in frame. Linkage bars are .125" thick plated steel

**Heat Responsive Devices:** Fusible links - 165°F and 212°F  
Heat Sensor - 165°F, 212°F and 350°F

**Finish:** Mill galvanized

**Spring:** Stainless steel

**Sizes:** Minimum size: 8" W x 6" H

Maximum UL Listed size:

Single section: 36" W x 36" H

Multiple assembly:

Vertical: 72" W x 36" H

Horizontal: 72" W x 36" H

**Options:**

- Blade Position Indicator Switches
- Electric Heat Sensor     STOR     DTOR
- #20ga sleeve

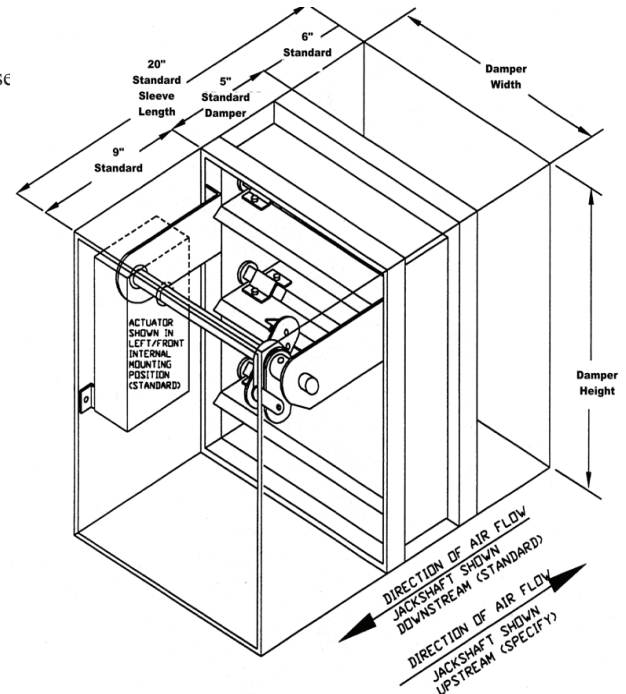

**Features:**

- The FSD-3V-231 series Combination Fire/Smoke Dampers have been designed and tested to exceed all U.L., U.L.C and N.F.P.A. requirements for fire dampers as well as to meet or exceed all U.L. (555S) and N.F.P.A. requirements for smoke dampers. They are intended for use where building codes call for the fire damper to also operate as a smoke damper.
- U.L. 555S and U.L.C. S112 listed and labeled as 3 hour fire damper.
- U.L. and U.L.C. listed for both vertical and horizontal mountings.
- U.L. 555S listed and labeled as a Leakage Class I rated (smoke) damper with airflow in both directions. Class I provides for a maximum leakage of 4cfm per sq. ft. at 1.0" static pressure and a maximum of 8cfm per sq. ft. at 4.0" static pressure. As we are constantly expanding our U.L./U.L.C. listings, we suggest you contact the factory for current information.
- Actuators shaft permits operation by any standard electric or pneumatic damper motor. Fusible link/actuator (DLT-1) provides an automatic override system to close and latch damper in the fire mode. Also available with automatic resettable / override release options: Model STO/R (single thermostat) or Model DTO/R (double thermostat) to provide the fire fighter with complete discretionary control of smoke functions during a fire/smoke emergency. (See STO/R and DTO/R submittal drawings for complete details.) Spring return type damper motor controlled by a smoke detector is recommended to provide proper operation in the smoke mode.

**SUGGESTED SPECIFICATIONS**

Combination Fire/Smoke Dampers shall be Model: FSD-3V-231. Fire/Smoke Dampers shall bear the Underwriters' Laboratories labels for both fire dampers and leakage rated (smoke) dampers. U.L. 555S rating shall be Class I with leakage in cfm per sq. ft. not to exceed 8 cfm per sq. ft. at 4.0 inches static pressure for any size. Linkage shall be of the concealed type for a maximum free area.

Duro Dyne National Corporate Headquarters, Bay Shore, NY  
631-249-9000 • Fax: 631-249-8346  
Duro Dyne Midwest • Duro Dyne West • Duro Dyne Canada  
www.durodyne.com • E-mail: durodyne@durodyne.com



**SUBMITTAL RECORD**

JOB \_\_\_\_\_  
LOCATION \_\_\_\_\_  
SUBMITTED TO \_\_\_\_\_  
SUBMITTAL PREPARED BY \_\_\_\_\_  
APPROVED BY \_\_\_\_\_  
DATE \_\_\_\_\_



**Submittal Form**

**FSD-3V-231**

**Combination Fire / Smoke Damper**

U.L. 555S Classified /

Class I U.L. 555 Classified 3 Hours

U.L.C. S112 Classified 3 Hours

Vertical and Horizontal Mountings

Pressure drop testing was done at the AMCA Laboratory to AMCA Standard 500, Fig. 5.3 ductwork upstream & downstream.

